

# GENERIC LIGHTING TOWER

---

Lighting Design Simulation Report

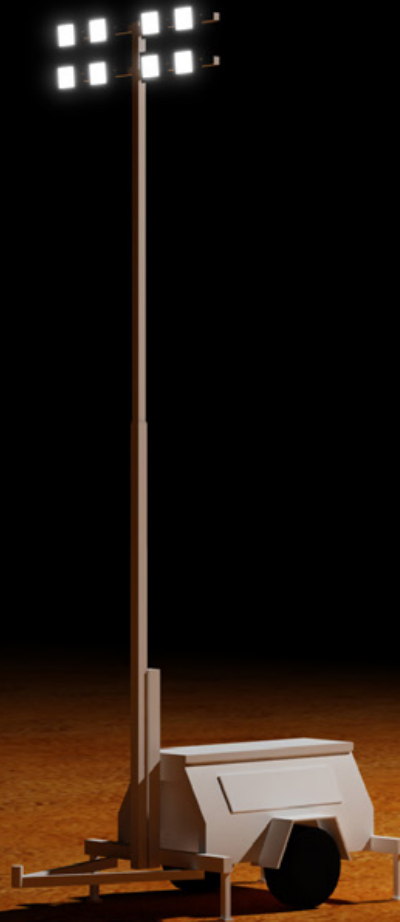

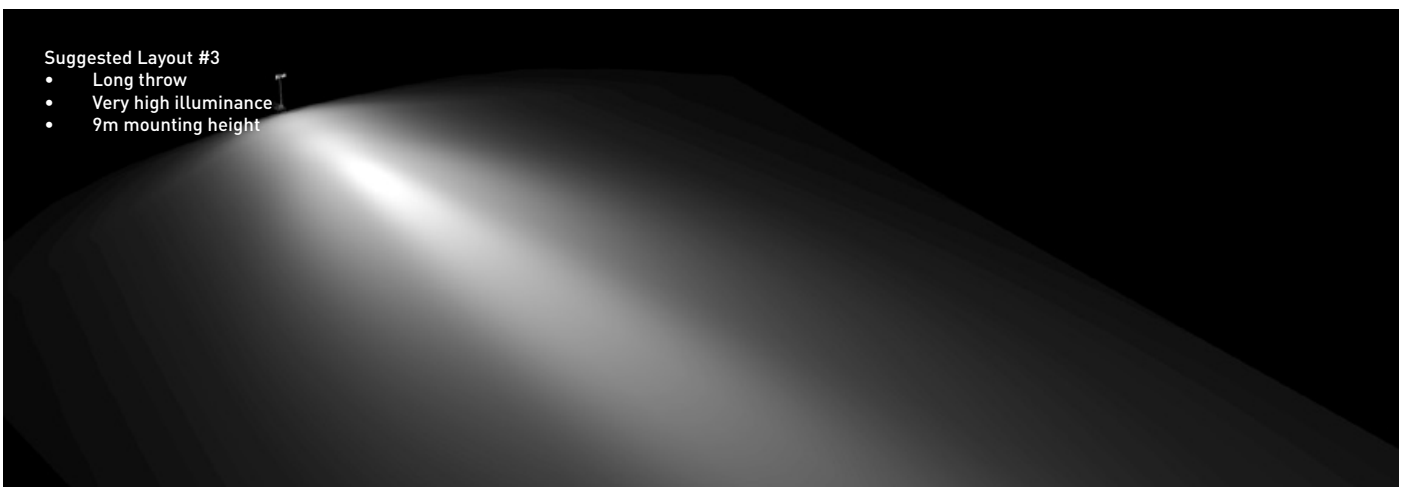
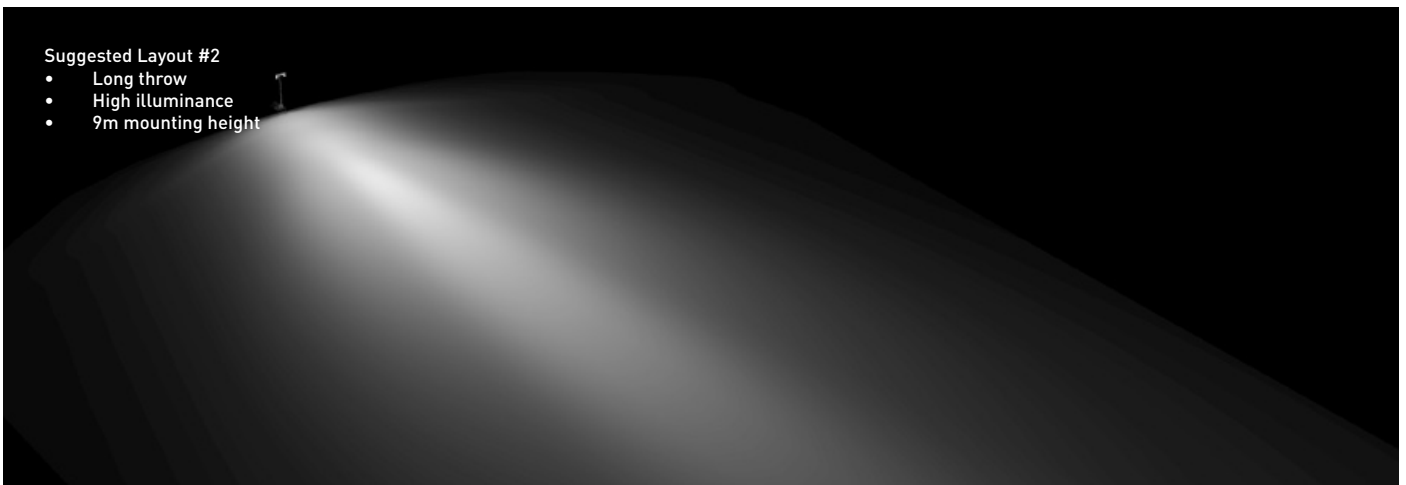
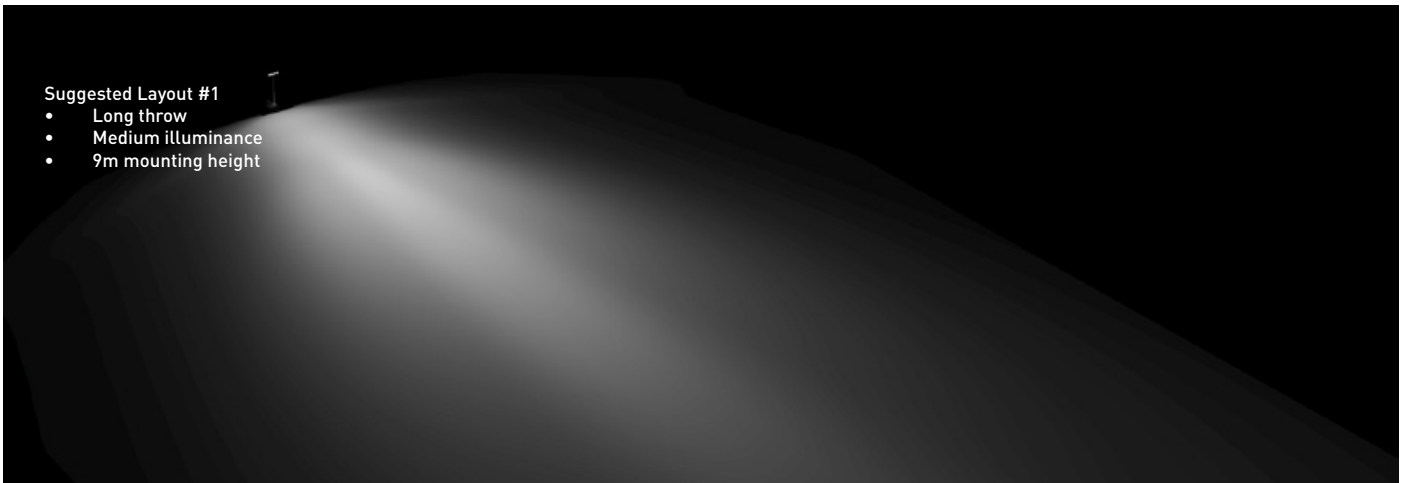

### SUGGESTED LAYOUT #1

Model No.	Luminaire	Optic Type	Quantity
CP56-0209-MPB-NPS	CP56 Flood Light	0209 - 40° x 18° Beam Angle	2
CP56-L07-MPB-NPS	CP56 Flood Light	L07 - 14° Beam Angle	2

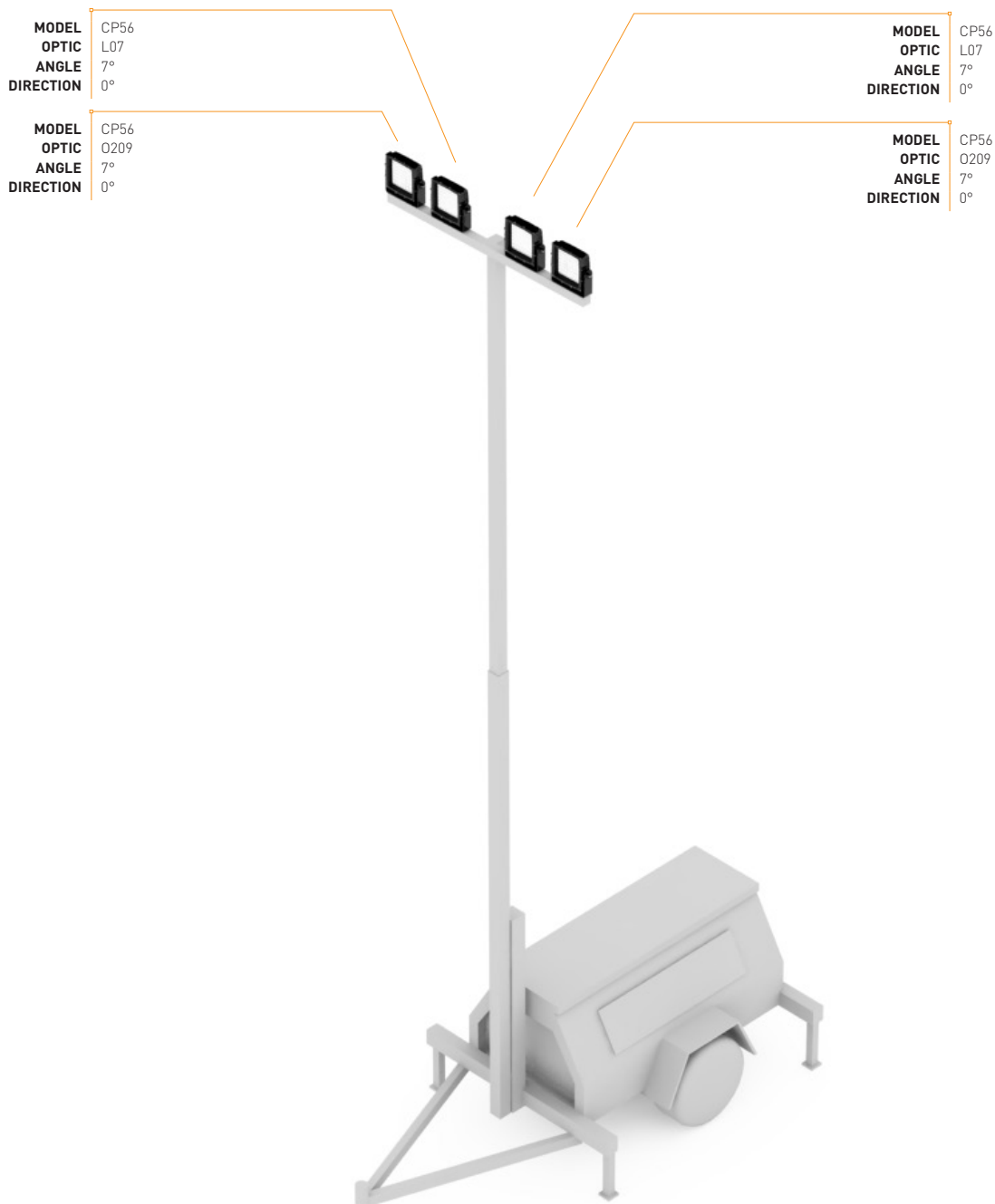

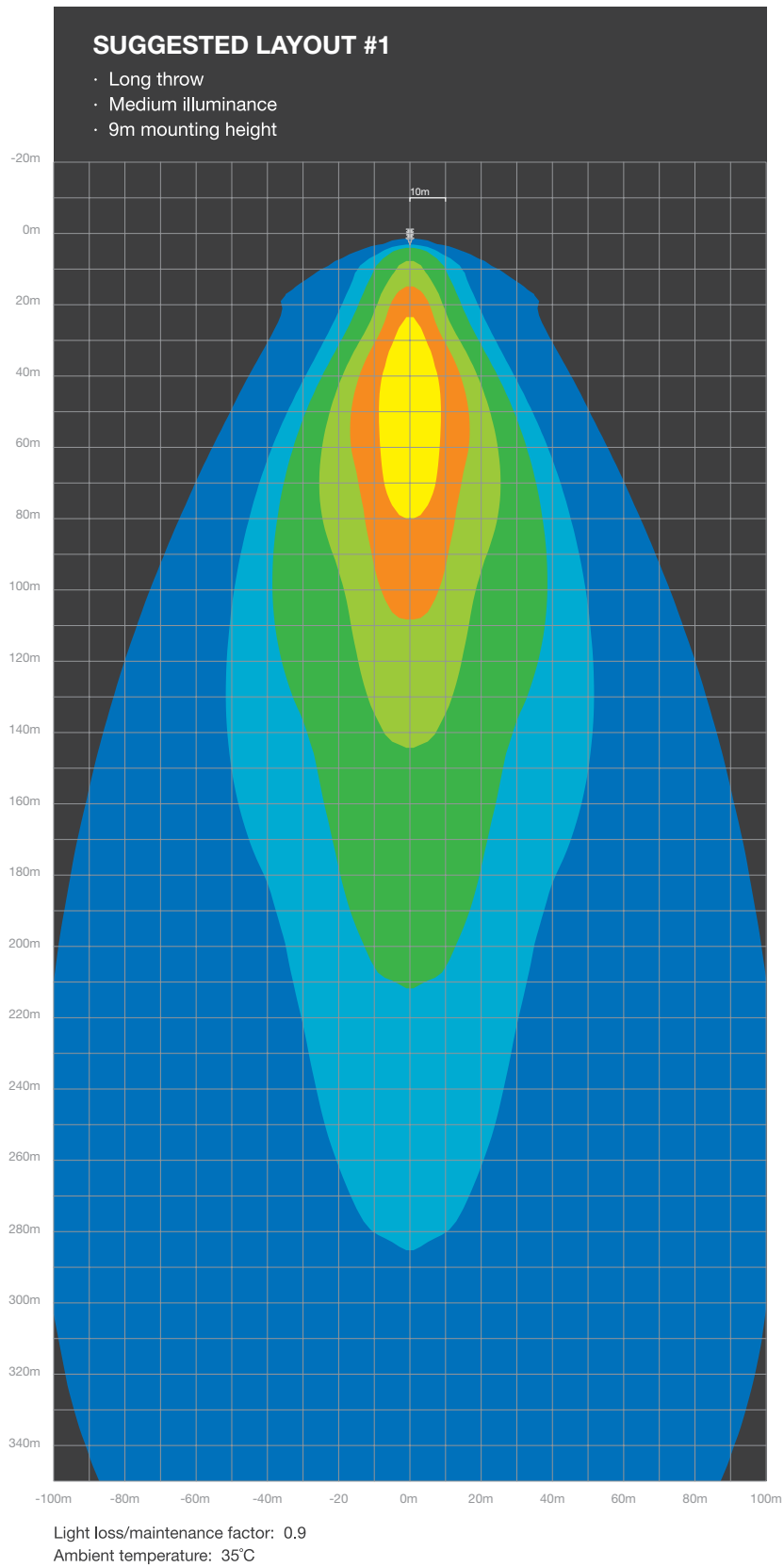

## SUGGESTED LAYOUT #2

Model No.	Luminaire	Optic Type	Quantity
CP56-0209-MPB-NPS	CP56 Flood Light	0209 - 40° x 18° Beam Angle	2
CP56-L07-MPB-NPS	CP56 Flood Light	L07 - 14° Beam Angle	4

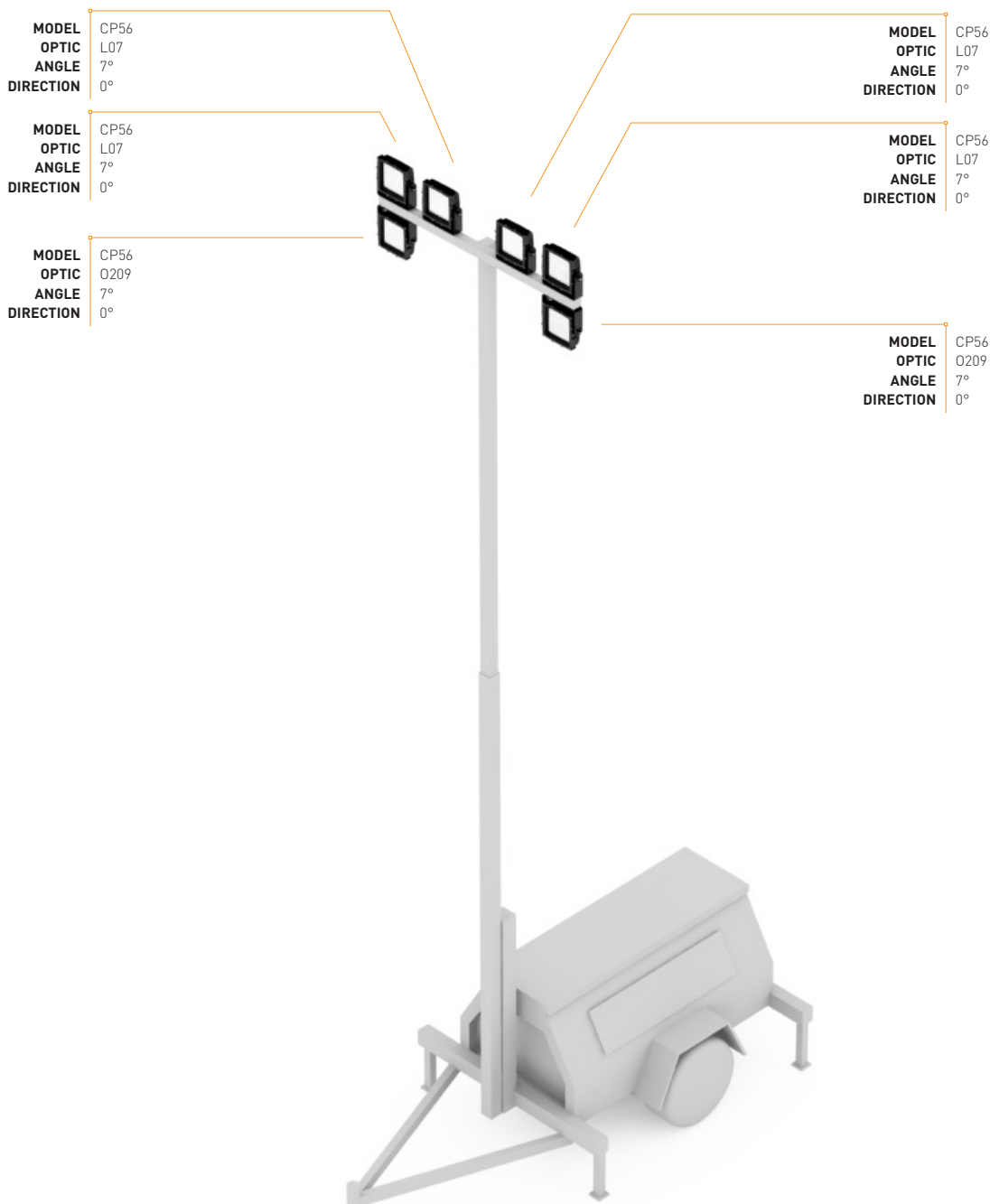

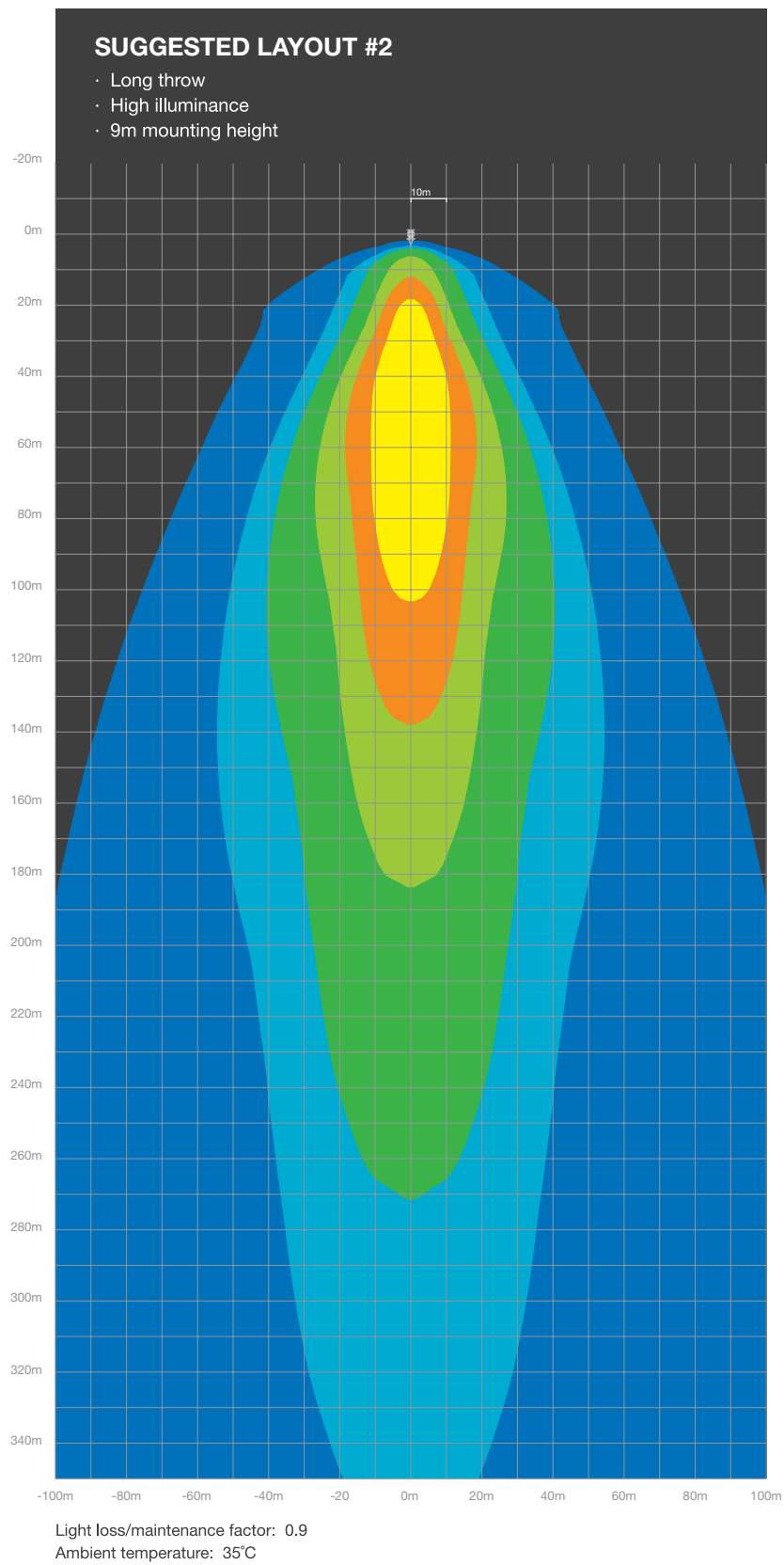

### SUGGESTED LAYOUT #3

Model No.	Luminaire	Optic Type	Quantity
CP56-0209-MPB-NPS	CP56 Flood Light	O209 - 40° x 18° Beam Angle	2
CP56-L07-MPB-NPS	CP56 Flood Light	L07 - 14° Beam Angle	6

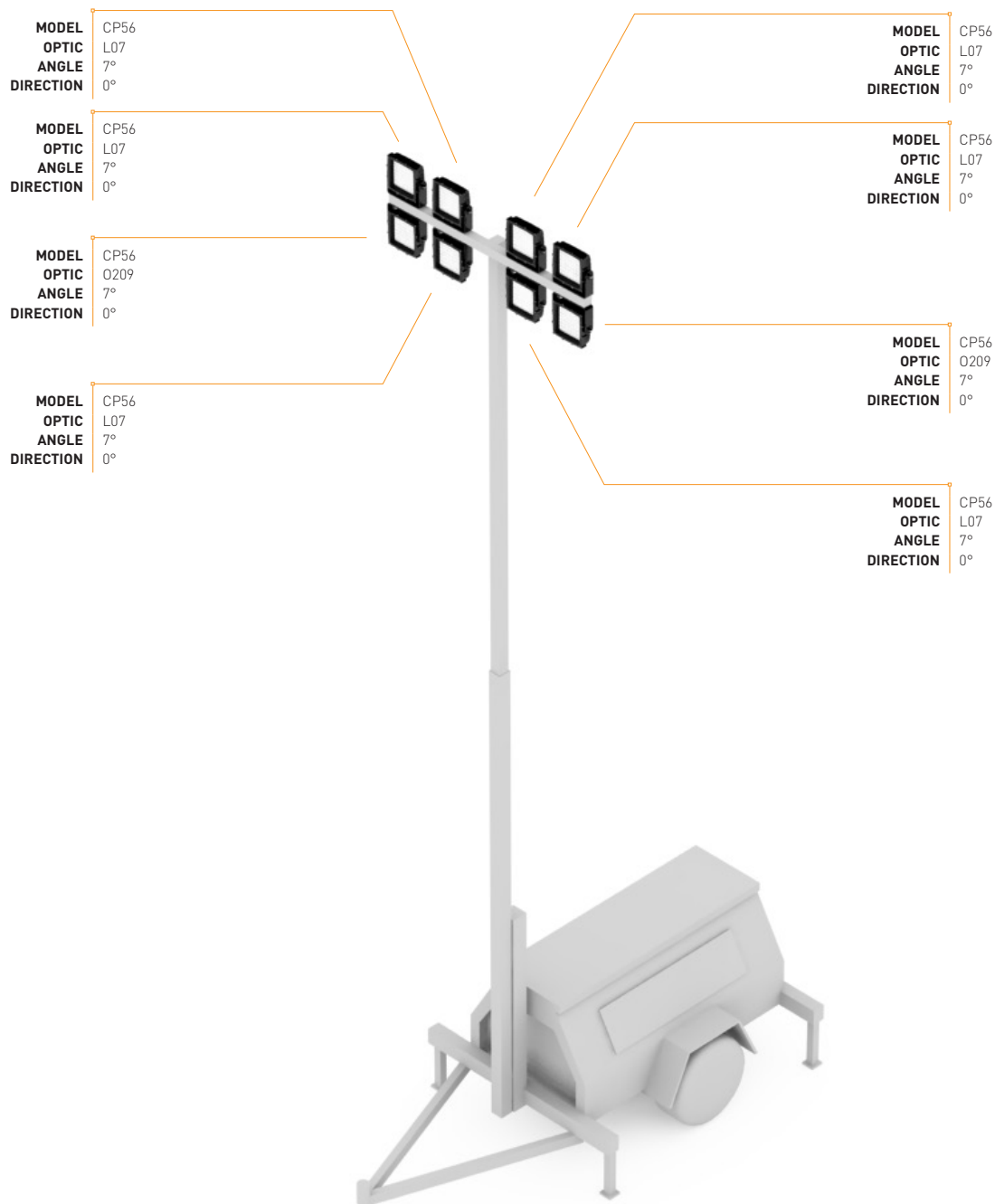

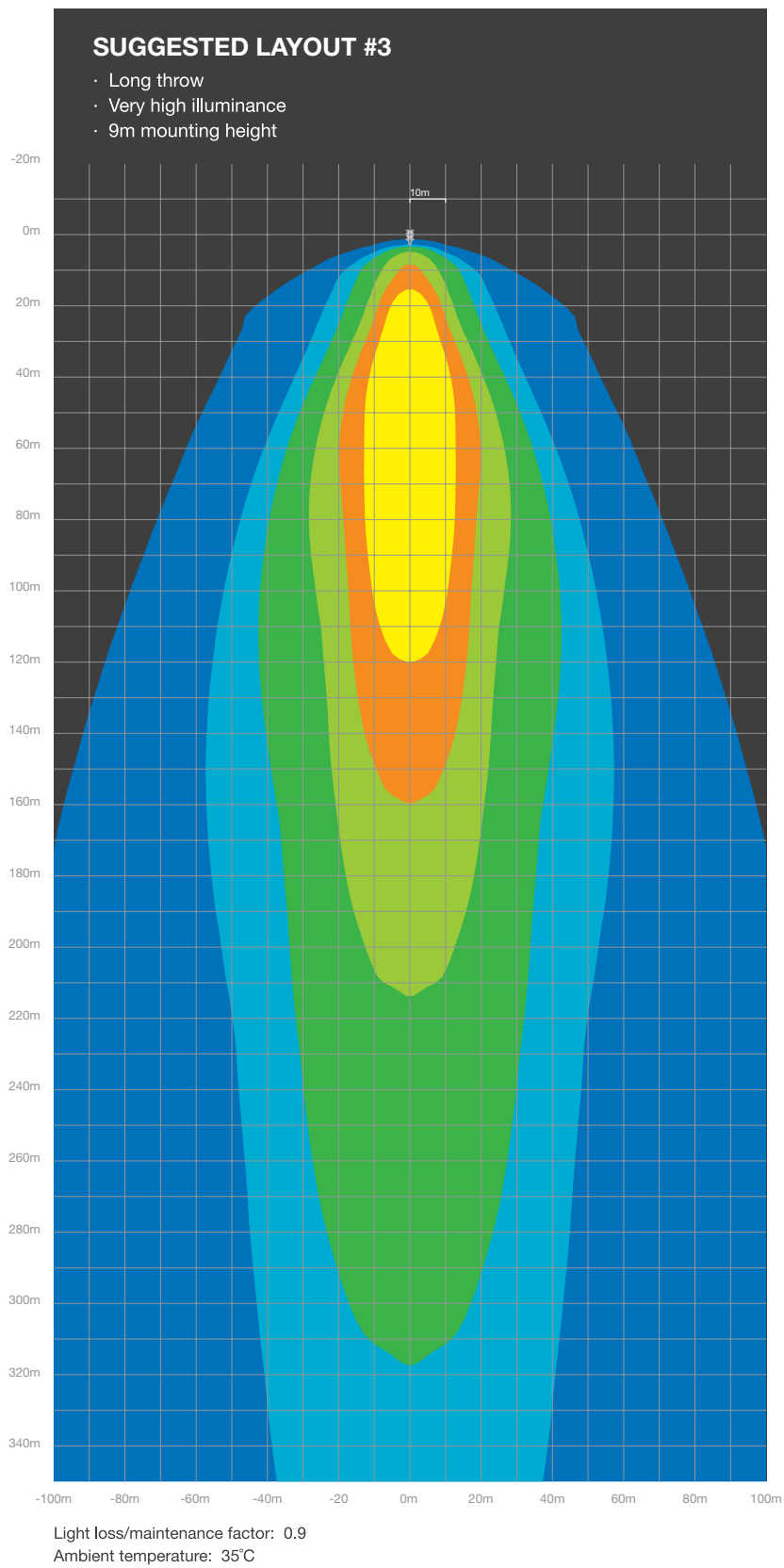

Suggested Layout #4

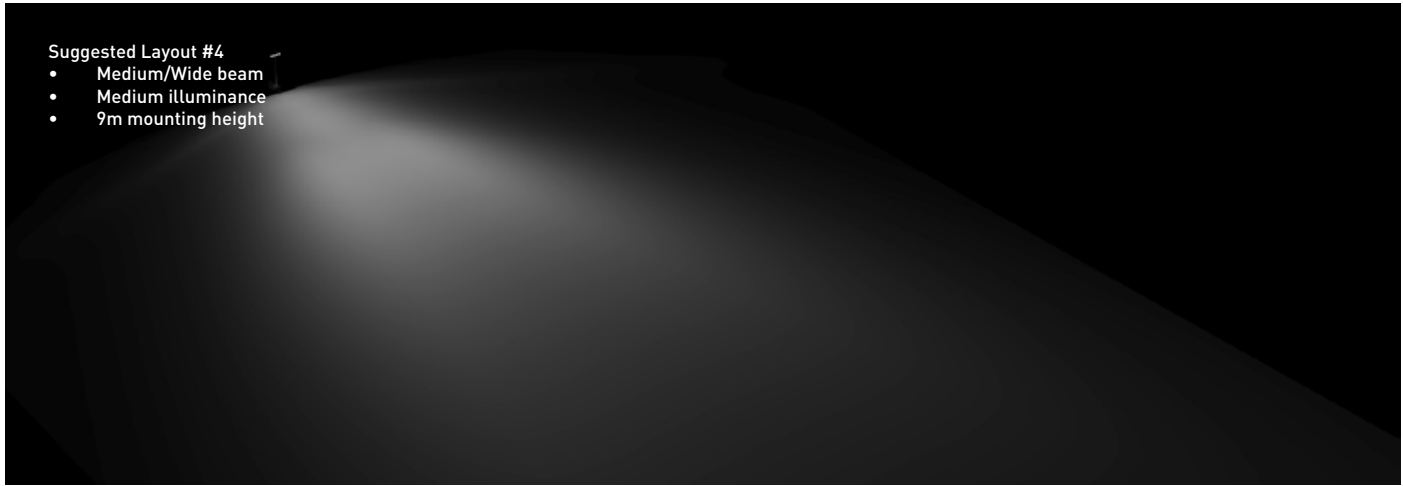
- Medium/Wide beam
  - Medium illuminance
  - 9m mounting height
- 

Suggested Layout #5

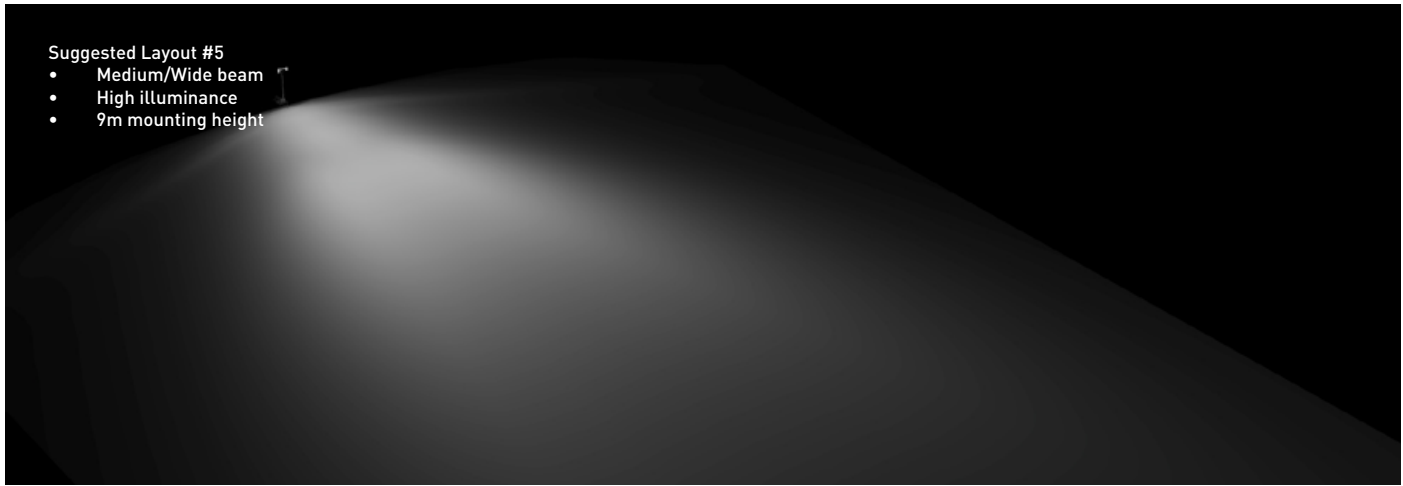
- Medium/Wide beam
  - High illuminance
  - 9m mounting height
- 

Suggested Layout #6

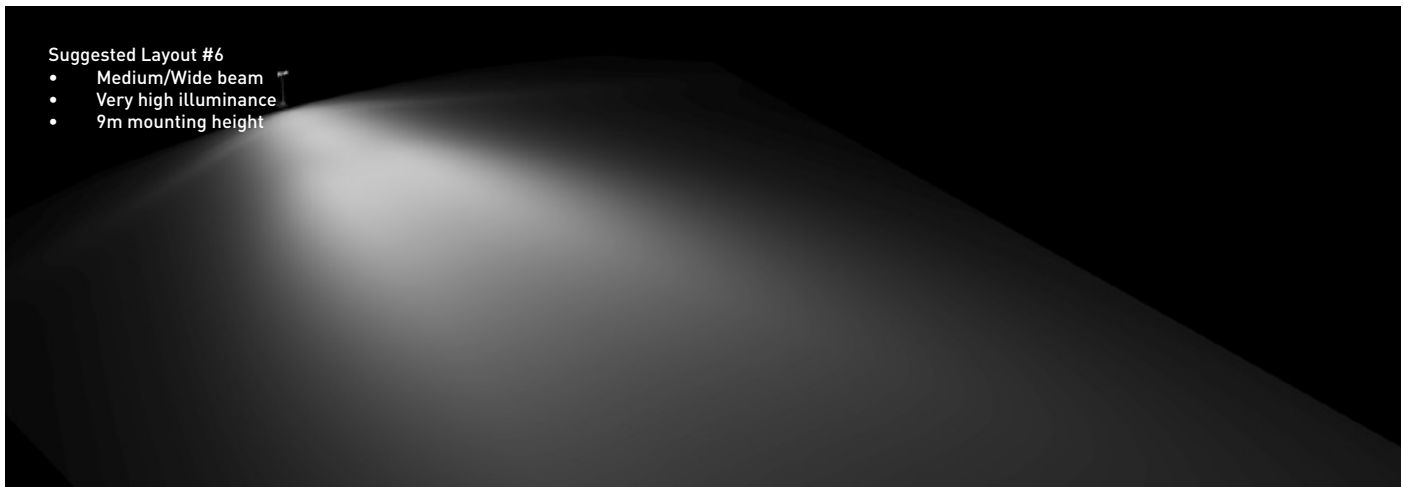
- Medium/Wide beam
  - Very high illuminance
  - 9m mounting height
- 

### SUGGESTED LAYOUT #4

Model No.	Luminaire	Optic Type	Quantity
CP56-0209-MPB-NPS	CP56 Flood Light	O209 - 40° x 18° Beam Angle	4

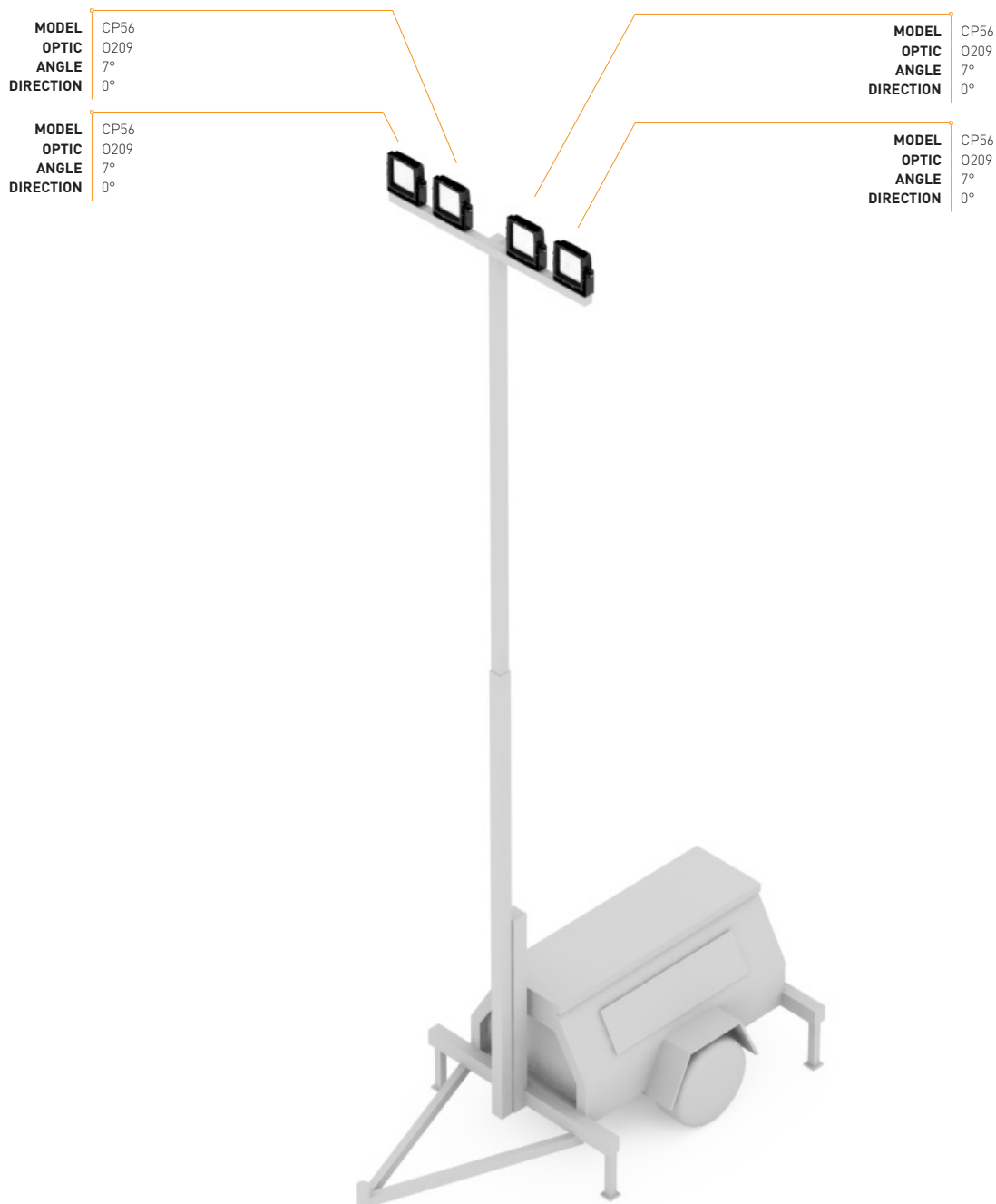

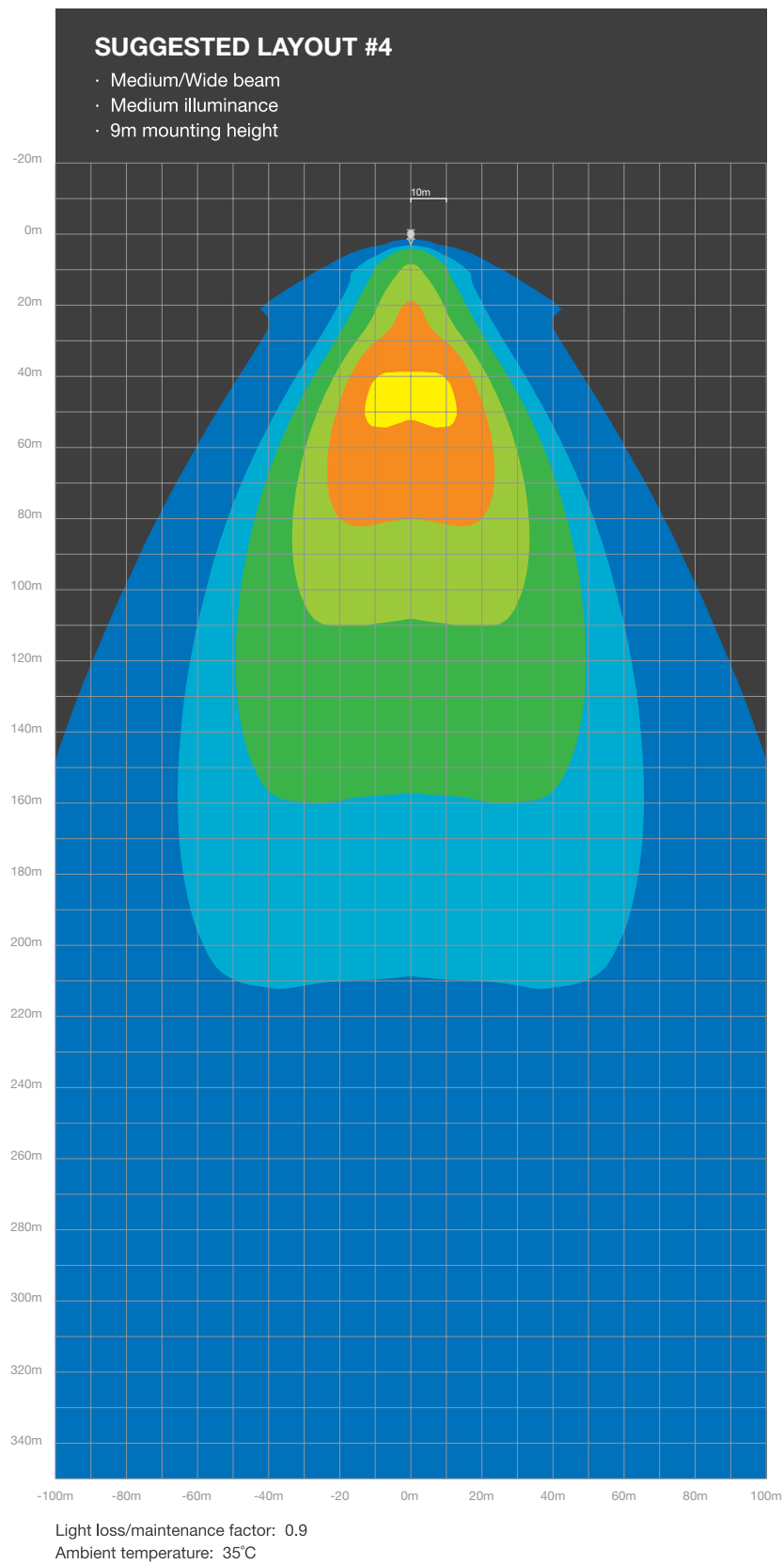

### SUGGESTED LAYOUT #5

Model No.	Luminaire	Optic Type	Quantity
CP56-0209-MPB-NPS	CP56 Flood Light	0209 - 40° x 18° Beam Angle	6

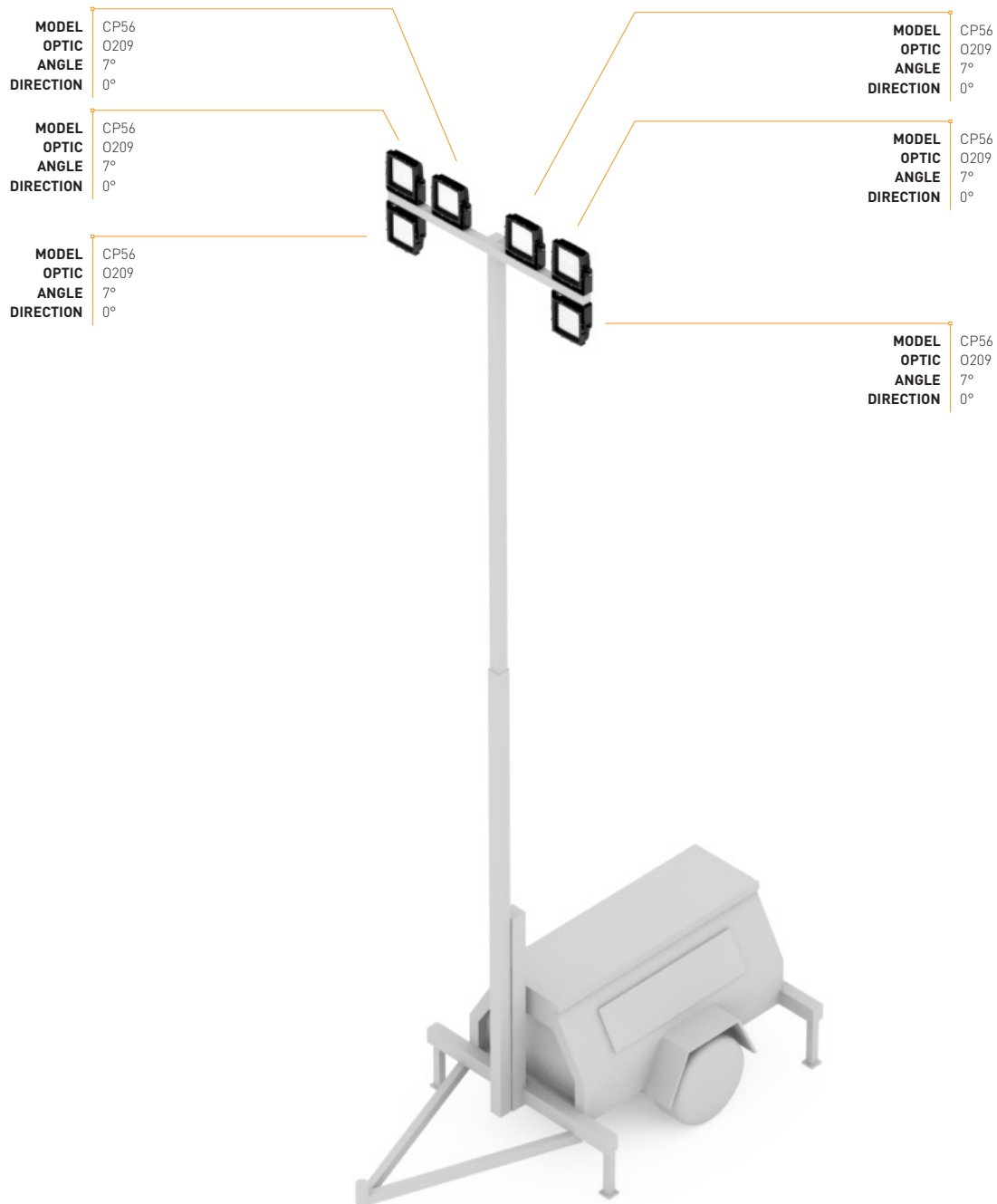

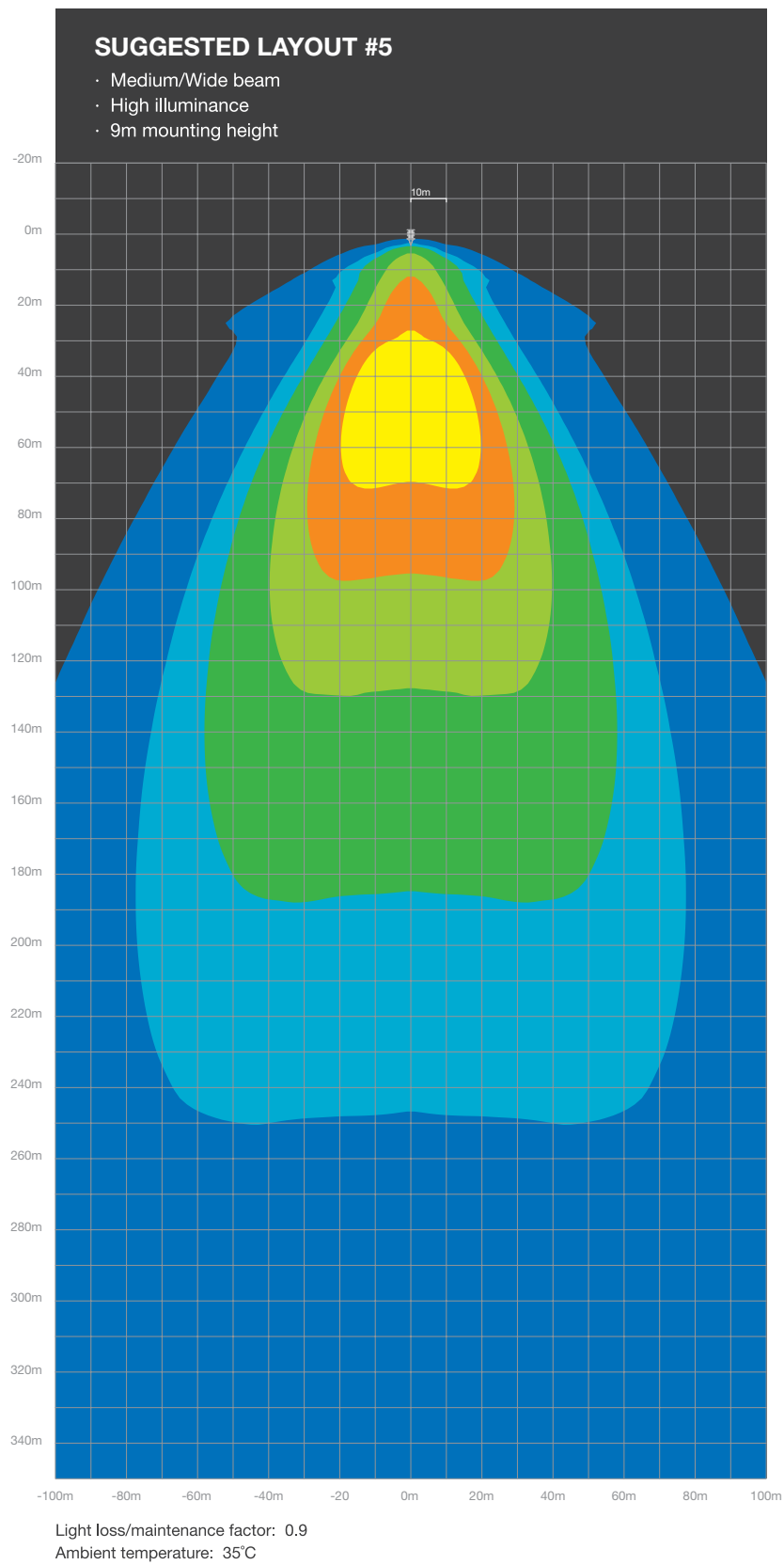

### SUGGESTED LAYOUT #6

Model No.	Luminaire	Optic Type	Quantity
CP56-0209-MPB-NPS	CP56 Flood Light	O209 - 40° x 18° Beam Angle	8

